

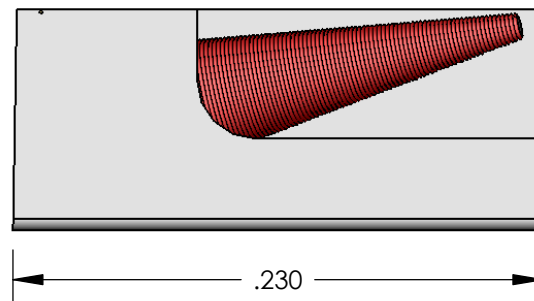

PICONICS

CC110T47K240G5-C

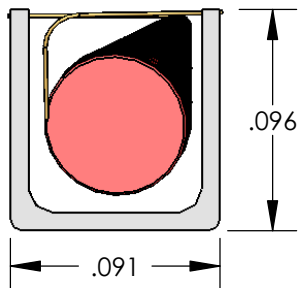
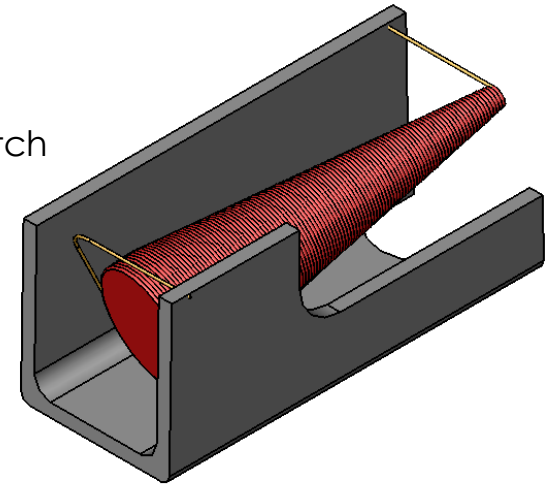
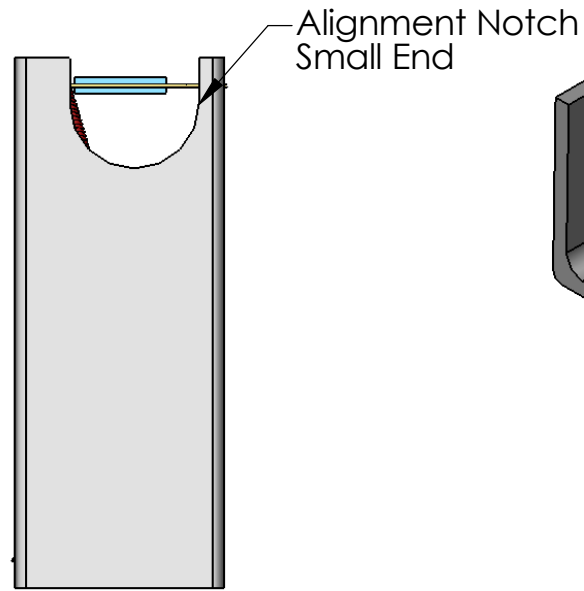
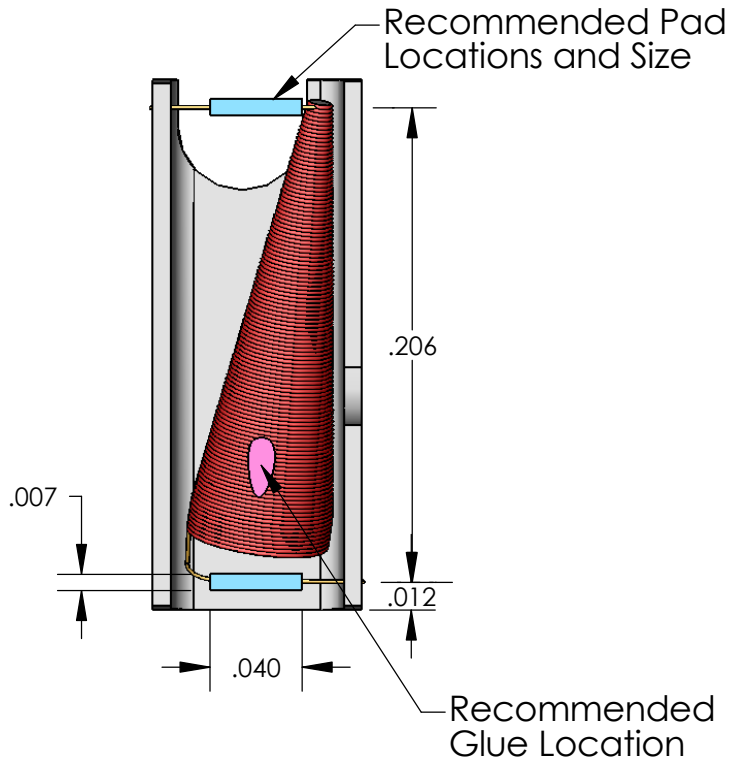

Electrical

Frequency:	10 MHz-40+ GHz
Return Loss:	-26dB typ. In/Out
Insertion Loss:	-.35dB typ.
Q Typ. @ 10 MHz:	25-30
I _{dc} (max):	100 mA
L @ 10 MHz:	8.00 μH
Fill:	Powdered Iron (S class)
Leads:	5-10uin Gold Plated
DCR Typ:	6.55 ohms